

RT 396

Pump and valves and fittings test stand



Description

- plotting characteristics of industrial valves and fittings
- comparison of different valves and fittings
- characteristics of a centrifugal pump

RT 396 allows the characteristics of different valves and fittings to be compared. The typical kinds of valves and fittings are represented by a ball valve, a butterfly valve, a gate valves, a shut-off valve and a control valve. A safety valve and a dirt trap are also investigated. All valves and fittings are flanged, and can be installed in a pipe section with variable length. The pipe section is part of a closed water circuit. Pressure measurement points upstream and downstream of the valve and fitting under test are linked by a differential pressure manometer. This manometer is fitted with a pressure switch which activates a warning lamp if the pressure difference becomes excessive, such as when the filter is clogged. An electromagnetic flow rate sensor permits precise recording of the flow rates.

The closed water circuit contains three butterfly valves, to isolate the pump, and to adjust the pressure upstream and downstream of the test fitting. Differential pressures across the pump and test fitting, the power consumption and speed of the pump, and the flow rate and opening angle of the control valve are recorded and displayed. The measured data can also be used to plot pump characteristics.

A vice is included, on a separate workbench, for maintenance and assembly work. The workbench also incorporates the necessary tools and connecting hoses.

Learning objectives/experiments

- characteristics of a centrifugal pump
- behaviour during operation and function of
 - ▶ ball valve
 - ▶ butterfly valve
 - ▶ shut-off valve
 - ▶ wedge gate valve
 - ▶ control valve
 - ▶ safety valve
 - ▶ dirt trap
- valve characteristics
- determining the K_{vs} value of the control valve
- pressure losses at the dirt trap depending on the filter and its load
- planning, execution and assessment of maintenance and repair operations
- reading and understanding engineering drawings and operating instructions

RT 396

Pump and valves and fittings test stand

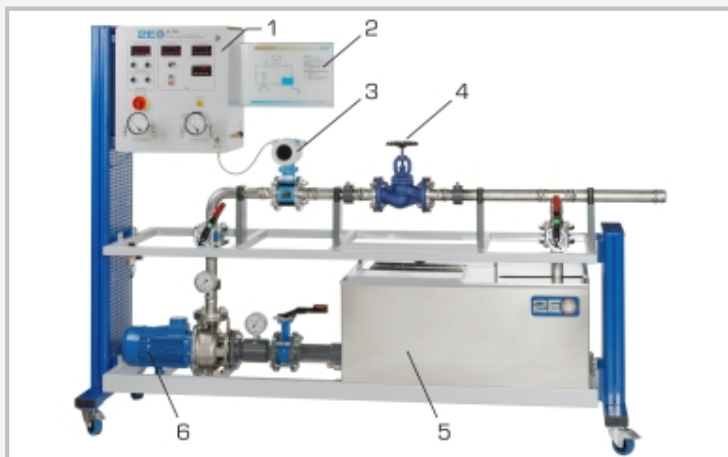

1 switch cabinet with displays and controls, 2 process schematic, 3 flow rate sensor, 4 pipe section with place for test fitting, 5 supply tank, 6 pump



Supplied valves and fittings: 1 dirt trap, 2 ball valve, 3 safety valve, 4 butterfly valve, 5 shut-off valve, 6 wedge gate valve, 7 control valve

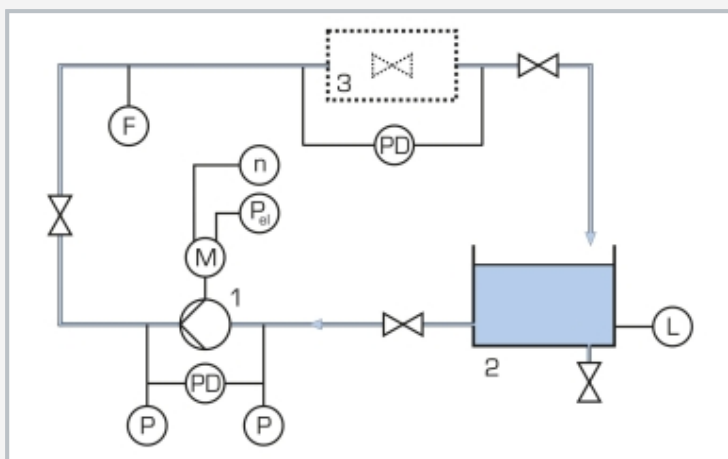

1 pump, 2 tank, 3 test fitting;
sensors: E power, F flow rate, L level, P pressure, PD differential pressure, n speed

Specification

- [1] trainer for testing various valves and fittings
- [2] installation of the test fitting in a pipe section of variable length
- [3] centrifugal pump with variable speed via frequency converter
- [4] fine pressure regulator adjusts compressed air pressure
- [5] tank cover as collecting tray under test device
- [6] manometers at inlet and outlet of centrifugal pump
- [7] pressure measuring points upstream and downstream of test device for differential pressure manometer with pressure switch
- [8] digital displays for flow rate, power output, speed, position of control valve

Technical data

Centrifugal pump

- power consumption: 4kW
- max. flow rate: 72m³/h
- max. head: 26,5m
- speed: 1450...2900min⁻¹

Supply tank with cover: capacity: 400L

Test valves and fittings:

- safety valve 1", 1,5bar
- shut-off valve DN50 / PN16
- ball valve with pneumatic drive DN50
- butterfly valve DN50 / PN16
- wedge gate valve DN50 / PN16
- electric control valve DN50 / PN16
- dirt trap DN50 / PN16 with 2 filter elements

Measuring ranges

- differential pressure manometer: 0...2,5bar / 0...4bar
- manometer: 0...4bar / -1...0,6bar
- flow rate: 35...1100L/min
- opening range of control valve: 0...100%
- power output: 0...4000W
- speed: 0...2900min⁻¹

400V, 50Hz, 3 phases

400V, 60Hz, 3 phases

LxWxH: 2510x790x1900mm (test stand)

Weight: approx. 245kg (test stand)

LxWxH: 1200x670x1100mm (workbench)

Weight: approx. 100kg (workbench)

Required for operation

Compressed air supply 8bar

Scope of delivery

- 1 trainer with centrifugal pump
- 1 control valve, 1 dirt trap, 1 safety valve, 1 shut-off valve, 1 ball valve, 1 butterfly valve, 1 wedge gate valve
- 1 workbench with tools and hoses
- 1 set of instructional material