

# ET 220.01

## Wind power plant



### Learning objectives/experiments

- conversion of kinetic wind energy into electrical energy
- design and function of a wind power plant in stand-alone operation
- energy balance of a wind power plant under real wind conditions
- GUNT E-Learning
  - ▶ multi-media online course on the fundamentals of wind power
  - ▶ learning independent of time and place
  - ▶ access via Internet browser
  - ▶ check through targeted review of the learning objectives

### Description

- practical experiments under real wind conditions
- wind power plant with rectifier and mechanical capacity controller
- easier installation due to removable supports and hinged mast
- connection to ET 220 or ET 220.10

The yield of a wind power plant depends on the prevailing wind velocities and the usability of the electricity generated. In order to study the operation of a wind power plant under real weather conditions, ET 220.01 was developed. ET 220.01 can be operated with the trainer ET 220 or the control unit ET 220.10.

The ET 220.01 wind power plant consists of an engine room, also called a nacelle, mounted on a pivoting mast with a stable base and supports. The speed of the rotor and the wind velocity are measured. These measured values are displayed on the control unit and in the software of ET 220 or ET 220.10. The control unit of ET 220 or ET 220.10 measures the generator's current and voltage. It is also possible to connect the accompanying battery to the wind power plant via a charge controller.

The rotor is aligned to the wind direction by means of a vane on the nacelle. The rotor hub contains a mechanical capacity controller that uses rotor blade adjustment. The wind power plant generates a direct current at a wind velocity of about 5m/s. A rectifier is integrated in the nacelle.

Before commissioning, ET 220.01 must be connected to the control unit of ET 220 or ET 220.10. Cables are provided for this purpose, separated for the sensors and the generated electricity. It is easy to change the location of the ET 220.01 wind power plant. To do this, the device is dismantled and can easily be transported on rollers. The device is weather resistant so that it can also be operated in bad weather periods over several days.

# ET 220.01

## Wind power plant

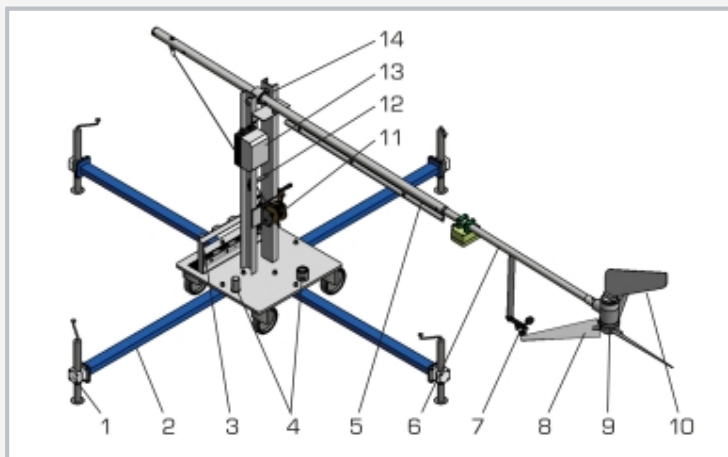

ET 220.01 with mast lying down

1 support leg, 2 mast support, 3 holder for mast supports, 4 holder for mast parts, 5 mast midsection with cable guide, 6 mast top with nacelle, 7 anemometer, 8 rotor blade, 9 engine room, 10 vane, 11 winch, 12 securing bolts, 13 junction box with transducers, 14 tilt axis

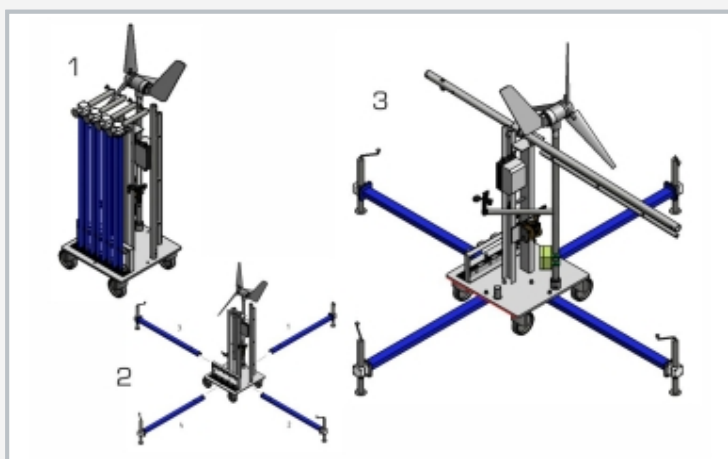

1 transport state, 2 assembling the mast supports, 3 assembling the mast

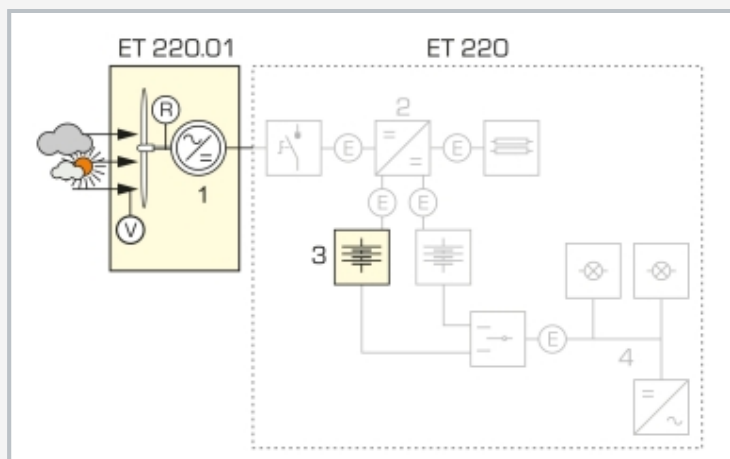

1 wind power plant with rectifier, 2 charge controller (ET 220/ET 220.10), 3 accumulator, 4 consumer (ET 220/ET 220.10); v wind velocity, R rotor speed, E current and voltage

### Specification

- [1] wind power plant for converting kinetic wind energy into electrical energy
- [2] remote learning: detailed E-Learning course on the basics of wind power accessible online
- [3] movable wind power plant that can be set up outside
- [4] 4 base supports for stabilisation
- [5] stand-alone operation with connection to ET 220 or ET 220.10
- [6] generator for converting kinetic energy into electrical energy
- [7] accumulator for storing the electrical energy
- [8] measurement of wind velocity
- [9] measurement of the rotational speed of the rotor
- [10] display of the measured data on the control unit of ET 220 or ET 220.10

### Technical data

#### Rotor

- Ø 1200mm
- hub height above ground level: approx. 5000mm

#### Generator

- max. output: 350W
- voltage: 12VDC
- max. charging current: 30A

#### Accumulator

- voltage: 12VDC
- capacity: 65Ah

#### Space requirement

- LxWxH: 10x6x6m
- max. distance from ET 220/ET 220.10: approx. 20m

#### Measuring ranges

- wind velocity: 0,7...50m/s
- speed: 0...3000min<sup>-1</sup>

LxWxH: 3500x3500x5600mm (with base supports)

Weight: approx. 340kg

### Scope of delivery

- 1 wind power plant
- 1 mast base
- 1 mast
- 4 base supports
- 1 accumulator
- 1 set of screws
- 1 set of tools
- 1 set of instructional material

# ET 220.01

## Wind power plant

Required accessories

ET 220                    Energy conversion in a wind power plant  
or  
ET 220.10              Control unit for wind power plant ET 220.01