

## ET 630

### Split system air conditioner



#### Description

- modern air conditioning unit with heat pump function: cooling and heating
- six different operating modes

Split system air conditioners are used to cool, dehumidify and also heat rooms. They consist of an inner and outer unit.

In the inner unit there is a heat exchanger with fan working as an evaporator in the refrigeration circuit during cooling operation. During heating operation it works as a condenser. The outer unit contains a compressor, another heat exchanger, expansion element (e.g. capillary tube) and an element enabling the change-over from cooling to heating operation. In cooling operation the evaporating refrigerant in the heat exchanger of the inner unit withdraws heat from the room air. In the outer unit the heat in the heat exchanger is discharged to the ambient air by condensing the refrigerant. During heating operation the heat transport is reversed.

ET 630 includes a dividing wall onto whose front and rear panel a modern split system air conditioner has been mounted. To better demonstrate its operation, an additional two pressure displays are available for the refrigerant. The operating mode, fan stage of the inner unit (fan operation) and desired room temperature are selected via a remote control. During automatic operation the actual room temperature is recorded and an operating mode automatically selected to achieve the specified room temperature.

In addition the following functions are set at the remote control: Timer for the regular switching on and off, single remaining operating time in hours (sleep mode; suitable for energy-saving operation) and horizontal position of the lamella at the air outlet for air distribution (swing mode; fixed or movable).

#### Learning objectives/experiments

- design and operation of a split system air conditioner
- 6 operating modes
  - ▶ cooling
  - ▶ dehumidifying (slight cooling)
  - ▶ heating
  - ▶ ventilation (only the fan of the inner unit)
  - ▶ automatic (operating mode suitable for the room temperature)
  - ▶ test of cooling function
- 3 additional functions
  - ▶ "sleep" (switch-off after several hours)
  - ▶ "swing" (air outlet lamella position)
  - ▶ timer for switching on and off
- remote control functions

# ET 630

## Split system air conditioner



1 air inlet inner unit, 2 air outlet inner unit, 3 switch cabinet, 4 manometer, 5 remote control, 6 outer unit, 7 dividing wall

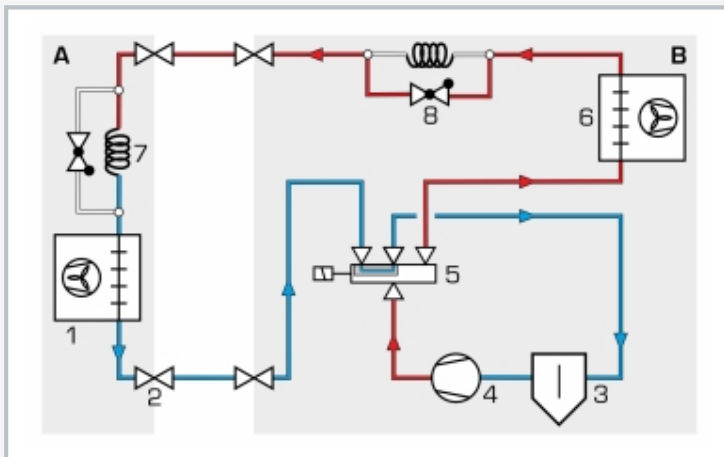

Exemplary process schematic: cooling process  
inner unit (A) and outer unit (B)  
1 heat exchanger inner unit, 2 valve, 3 liquid separator, 4 compressor, 5 reversing valve, 6 heat exchanger outer unit, 7 capillary tube, 8 non-return valve; red arrow: heating, blue arrow: cooling

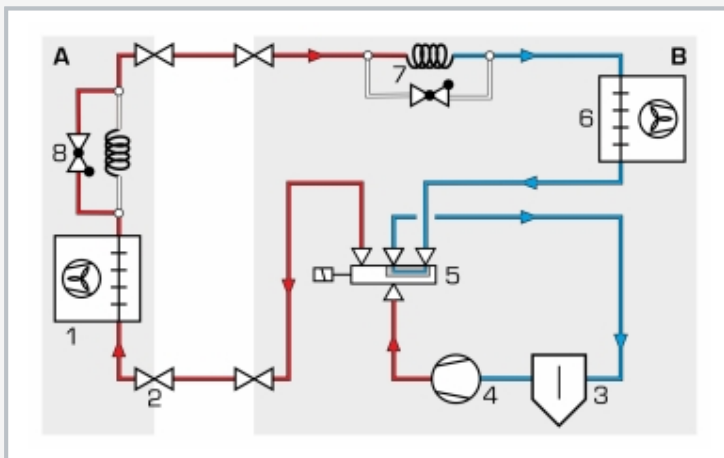

Exemplary process schematic: heating process  
inner unit (A) and outer unit (B)  
1 heat exchanger inner unit, 2 valve, 3 liquid separator, 4 compressor, 5 reversing valve, 6 heat exchanger outer unit, 7 capillary tube, 8 non-return valve; red arrow: heating, blue arrow: cooling

### Specification

- [1] trainer from the GUNT practical series for the training of mechatronics engineers for refrigeration
- [2] design and operation of a commercial split system air conditioner
- [3] illustration of the split principle using a dividing wall
- [4] 6 different operating modes: heating, cooling, dehumidifying, ventilation, automatic, test
- [5] 3 additional functions configurable via remote control: sleep, swing, timer
- [6] 2 refrigerant manometers indicate the low and high pressure of the compressor
- [7] refrigerant R32, GWP: 675
- [8] battery operated remote control

### Technical data

#### Split system air conditioner

- power consumption: approx. 1,2kW at 24/35°C
- cooling capacity: approx. 3,5kW at 24/35°C
- heating power: approx. 4,0kW bei 24/35°C
- max. volumetric air flow rate (inner unit): approx. 420m<sup>3</sup>/h
- dehumidification (inner unit): approx. 0,8L/h
- timer: 24h

#### Refrigerant

- R32
- GWP: 675
- filling volume: 700g
- CO<sub>2</sub>-equivalent: 0,5t

#### Measuring ranges

- pressure: 2x -1...40bar

230V, 50Hz, 1 phase

230V, 60Hz, 1 phase; 120V, 60Hz, 1 phase

UL/CSA optional

LxWxH: 1000x1000x1500mm

Weight: approx. 80kg

### Scope of delivery

- 1 trainer
- 1 remote control
- 1 manual