

HL 320.05

Central storage module with controller



The illustration shows HL 320.05 with the switch box for HL 320.02; display of the heating controller's user interface on any number of end devices

Description

- **buffer storage and bivalent storage for heating systems with renewable energies**
- **heating controller with data logger and integrated WLAN router for operation via web browser**
- **network capability: observe, acquire, analyse experiments via customer's own network**
- **pump with speed control and driven three-way valve for various configurations**

The HL 320 modular system allows experiments on the generation, storage and use of heat from renewable energies. A variety of heat sources, storage types and consumers can be used. The system uses typical real-world components from the field of modern heating technology.

The HL 320.05 central storage module forms the core of the HL 320 modular system and contains piping, a pump, a driven 3-way valve and safety devices. Two different heat storage methods are available. Quick-release couplings on the front of the module enables the hydraulic connection to other modules of the HL 320 modular system.

The freely programmable heating controller allows you to operate and study all intended HL 320 modular combinations. The heating controller is operated via touch screen or web browser with LAN/WLAN connection. An integrated WLAN router enables access to ongoing experiments from any number of external workstations. Different user levels with different functions can be selected. A LAN/WLAN connection with the local network allows the evaluation of the recorded measured values on a PC. An additional manufacturer software of the heating controller is supplied for this purpose.

Thoroughly documented configuration files for introductory and advanced experiments are available for all recommended HL 320 modular combinations. Newly created configurations or changes can be stored in the controller's memory. For editing the configuration files, the manufacturer also provides clear software.

Learning objectives/experiments

- the following learning objectives can be worked through, depending on the selected HL 320 modular combination:
 - ▶ familiarisation with modern heating systems based on renewable energy sources
 - ▶ commissioning of heating systems with solar thermal energy and heat pump
 - ▶ electrical, hydraulic and control engineering operating conditions
 - ▶ properties of various heat storage methods
 - ▶ creation of energy balances for different system configurations
 - ▶ development of control strategies for different operating modes

HL 320.05

Central storage module with controller



1 fresh water inflow, 2 temperature sensor, 3 bivalent storage, 4 bleed valve, 5 pressure relief valve, 6 freely programmable heating controller: : operation via touch screen or web browser, 7 pressure sensor, 8 buffer storage

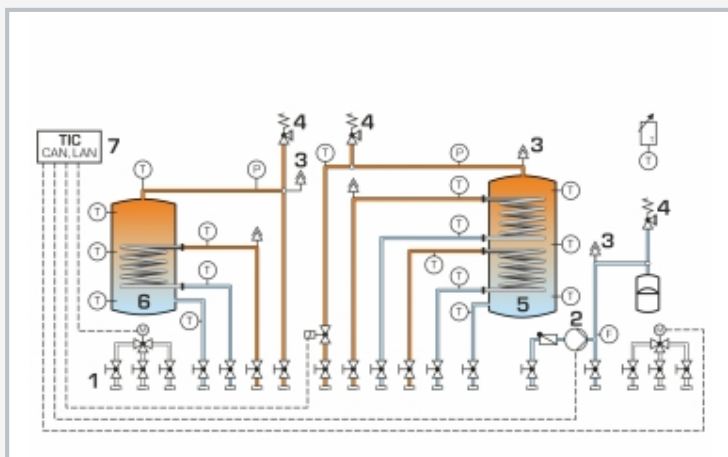

1 connections for heat transfer pipes with shut-off valves and quick-release coupling, 2 pump, 3 bleed valves, 4 pressure relief valves, 5 bivalent storage, 6 buffer storage, 7 TIC freely programmable heating controller; F flow rate, P pressure, T temperature

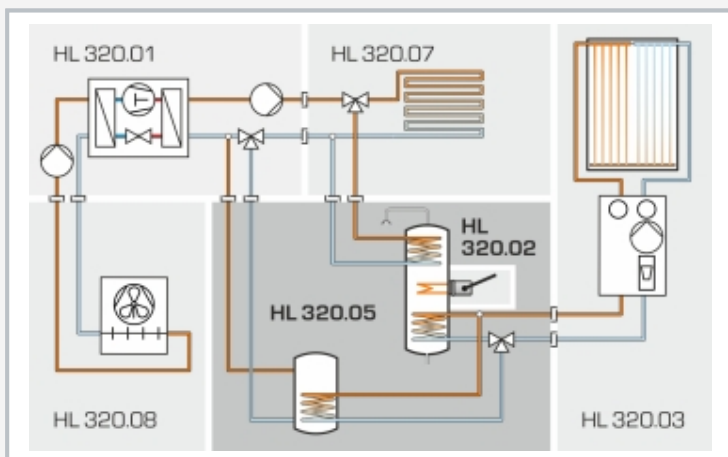

Inclusion of HL 320.05 in one possible configuration of the HL 320 modular system

Specification

- [1] buffer storage and bivalent storage for experiments with the HL 320 modular system
- [2] heat transfer pipes with quick-release coupling and shut-off valve
- [3] pressure relief and bleed valves for safe operation
- [4] circulating pump with adjustable speed
- [5] driven 3-way valves
- [6] temperature sensors for heat storage and room temperature
- [7] 2 pressure sensors for system monitoring
- [8] flow meters and temperature sensors for determining the heat flows
- [9] freely programmable heating controller with data logger, operation via touch screen or web browser with LAN/ WLAN connection
- [10] remote learning: integrated WLAN router for access to ongoing experiments from any number of external workstations
- [11] experiment evaluation with additional manufacturer software of the heating controller

Technical data

Buffer storage

- storage capacity: 150L
- number of heat exchangers: 1
- operating pressure: max. 5bar
- operating temperature: max. 95°C

Bivalent storage

- storage capacity: 200L
- number of heat exchangers: 2
- operating pressure: max. 5bar
- operating temperature: max. 95°C

Pump

- max. flow rate 3m³/h
- max. head: 4m

Heating controller

- inputs/outputs: up to 16 (expandable)
- interfaces: CAN, LAN

Measuring ranges

- temperature: 16x -50°C...180°C, 1x 0...40°C
- flow rate: 20...2500L/h
- pressure: 2x 0...6bar

230V, 50Hz, 1 phase; 230V, 60Hz, 1 phase
 120V, 60Hz, 1 phase; UL/CSA optional
 LxWxH: 2400x810x1900mm, Weight: approx. 220kg

Required for operation

PC with Windows

Scope of delivery

trainer, set of instructional material (with sample programs for the heating controller)

HL 320.05

Central storage module with controller

Required accessories

Combination 1

HL 320.03 Flat collector

Combination 2

HL 320.02 Conventional heating

HL 320.03 Flat collector

HL 320.07 Underfloor heating / geothermal energy absorber

Combination 4

HL 320.01 Heat pump

HL 320.03 Flat collector

HL 320.07 Underfloor heating / geothermal energy absorber

HL 320.08 Fan heater / air heat exchanger

Combination 5

HL 320.01 Heat pump

HL 320.02 Conventional heating

HL 320.03 Flat collector

HL 320.07 Underfloor heating / geothermal energy absorber

HL 320.08 Fan heater / air heat exchanger

Optional accessories

Combination 1, 2, 4, 5

HL 320.04 Evacuated tube collector

HL 313.01 Artificial light source